

**WARNING**

1. To avoid electric shock, disconnect power at source prior to installation.
2. The installation should be performed by qualified electricians or lighting technicians.
3. Before conducting any installation, maintenance, or removal, disable all power to the luminaires and wait until the fixture cool down.
4. Do not touch the fixture while it is in service.
5. If there is any problem with the fixture, DO turn off power and DO NOT attempt repair unless you are a qualified technician or the customer service member.

LEFT BACK VIEW OF FITTING

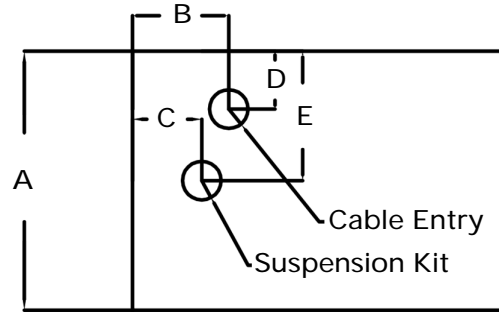
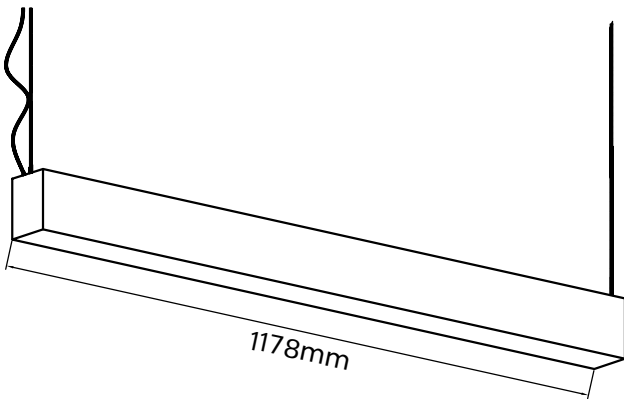

A	67mm
B	25mm
C	18mm
D	15mm
E	33.5mm

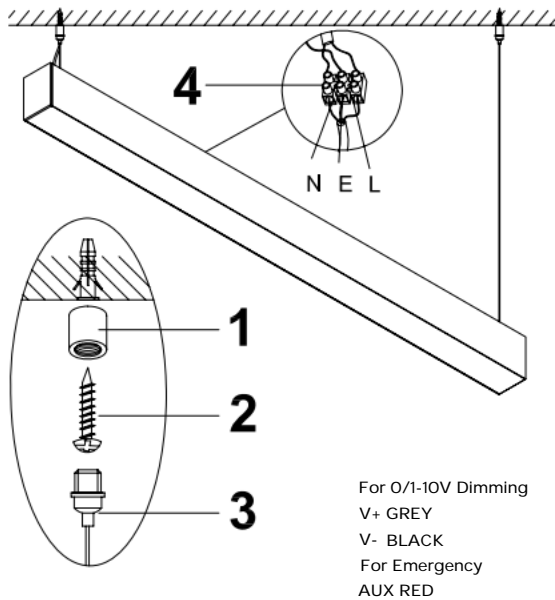

- Unscrew the mounting connector bottom (3) from the pre-assembled mounting connector.
- Drill mounting holes onto ceiling and install the mounting connector head (1) onto ceiling by screwing the tapping screws (2) provided into appropriately sized mounting screws and anchors. Ensure the mounting screws and anchors used are suitable for the mounting surface.
- Screw the mounting connector bottom (3) back to the mounting connector head. Ensure screws are tightened.
- Connect the mains supply wire to the fitting mains wire. Ensure that wires are secure and no bare wires are exposed.

Luminaire must be operated within an ambient fixture temperature of -20°C to 50°C to comply with all safety and warranty regulations. Ensure sufficient air flow around the for efficient heat dissipation. Failure to do so could significantly reduce luminaire life and/or safety/warranty regulations.

**NOTE: Installation of LED luminaire with modification to the unit, or incorrect fitting in accordance with the above instructions could result in damage/failure of the luminaire, which may invalidate warranty.**

MANUFACTURER'S GUARANTEE

This product is guaranteed in the country of purchase for the number of years as stated from the date of purchase. The guarantee is invalid in the case of improper use, installation, tampering, removal of the Q.C. date label, installation in an improper working environment or installation not in accordance with the advised instructions and/or national wiring regulations. Should this product fail during the guarantee period it will be replaced free of charge, subject to correct installation and return of the faulty unit. We not accept responsibility for any installation costs associated with the replacement of this product. This warranty is in addition to the statutory rights in your country of purchase and reserve the right to alter specifications without prior notice.